

## E3500 Chemilux

### Portable Advanced Dual-Mode Explosives Detector

**Introducing the E3500 Handheld Advanced Chemilux Dual-mode Trace Explosives Detector parented from Scintrex Trace, the most experienced designer and maker of advanced explosive and narcotic detection systems in the world.**

E3500 is the world's first portable explosives trace detector based on Luminol Chemilux. E3500 is the only portable device capable of detecting the presence of homemade, military and commercial explosives, including ICAO taggants, plastics, ammonium nitrate, black powder, other nitrates and TATP.

Portable, quick detection with clear, accurate results, with very high selectivity for explosives and immunity to humidity problems. E3500 detects traces of particulates and vapours of explosives, non-invasively in luggage, mail, cars, trucks, clothing, electronic articles, backpacks, documents and containers.

#### Operating the E3500

E3500 is flexible and easy to use, offering dual vapour and particulate detection without any external carrier gas or radioactive source. Vapours are sampled via the sampling nozzle. Particulates are sampled by swiping a suspected object and transferring any traces to the unit.

- ➔ **Fast and Proven:** E3500 detects plastic and high vapour pressure explosives quickly—giving clear results you can trust.
- ➔ **Sensitive and Selective:** E3500 can detect minute traces (low nanogram level) of C-4, TNT, Dynamite, PETN, Semtex, EGDN, DMNB, RDX, ANFO,

Black Powder, Ammonium Nitrate, Urea Nitrate, Nitroglycerine and TATP, with low false alarm levels and few interferences.

- ➔ **Portable:** E3500 is self-contained, lightweight, less than 3 kg (6.6 lbs), and comes in a fully equipped, rugged carrying case—field ready.
- ➔ **No Radioactive Isotopes or Radioactivity Period.**
- ➔ **Easy to Use:** E3500 is ready for field use within a minute from power-up. When necessary, cleaning only takes a few seconds. Simple push-button automatic operation displays go/no go result in just seconds on the LCD display.

**SECURITY  
DETECTION**  
METAL DETECTORS • X-ray MACHINES

*"Homeland Security Specialist"*

Boston, MA • Myrtle Beach, SC • Toledo, OH • Orlando, FL • Chicago, IL • Tulsa, OK • Los Angeles, CA

[www.securitydetection.com](http://www.securitydetection.com) • Tel: 800-930-3766

**The E3500 is ideal for:**

- Police & Bomb Squads
- Airports
- Customs
- Military Defense
- Seaports and Containerships
- Field or Forensic Use
- Nuclear Facilities
- Embassies or Consulates
- Courts of Law
- Postal Stations
- Corporate or VIP Headquarters
- Commercial
- Correctional
- Federal buildings
- Railway, Bus and Subway Terminals
- Special Events, Leases, Rentals

**...Worldwide**

**SPECIFICATIONS\***

<b>DETECTION PRINCIPLE</b>	Luminol Chemilux – Disposable cartridge
<b>NO RADIOACTIVITY</b>	No radioactive source, no licensing.
<b>DETECTABLE COMPOUNDS</b>	Most military (including plastic) and commercially available explosives, C4, TNT, Nitroglycerin, Dynamite, PETN, Semtex, RDX, ANFO, ICAO Taggants, (DMNB, EGDN, o-MNT, p-MNT), Urea nitrate, and TATP
<b>SAMPLING CAPABILITIES</b>	Vapours and particulates - Dual Mode
<b>TYPICAL SAMPLE/ANALYSIS TIME</b>	Sample: 5-30 seconds (user selectable based on application) Analysis: within 20 seconds
<b>INITIAL WARM-UP TIME</b>	60 seconds
<b>CARRIER GAS</b>	None required (ambient air)
<b>CONTROLS</b>	Power switch Keypad Automatic Vapour/Particulate selector Volume control (with optional earphone) Sample switch
<b>OPERATIONAL STATUS INDICATORS</b>	LED indicator lights Liquid Crystal Display (LCD) with graphic display
<b>DATA STORAGE + COMMUNICATIONS</b>	1000 retrievable data records RS-232 serial output port for remote control and monitoring
<b>POWER SUPPLY</b>	12 volt DC rechargeable battery pack External battery pack 12 volt AC adapter
<b>OPERATING + STORAGE TEMPERATURES</b>	Operating: 0°C to +55°C (+32°F to +131°F) Storage: 0°C to +65°C (+32°F to +149°F)
<b>WEIGHT + DIMENSIONS</b>	Unit weight: 3 kg (6.6 lbs.) in ABS engineered plastic shielded case Unit dimensions (LxWxH): 51x14x11 cm / 20x5.5x4.3" Shipping weight: 14 kg (31 lbs.) Shipping dimensions (LxWxH): 52x26x39 cm / 22x10x14"
<b>WARRANTY</b>	One year

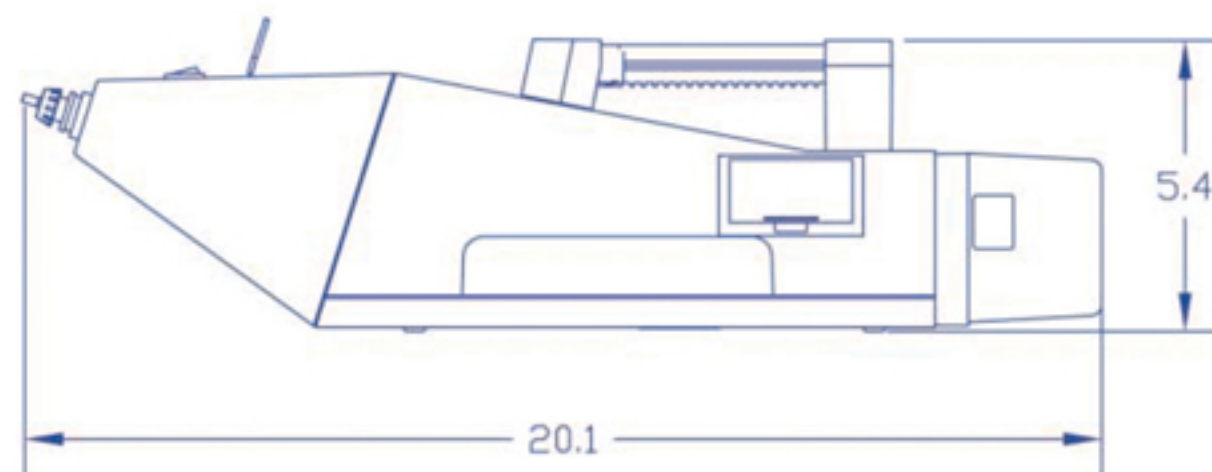
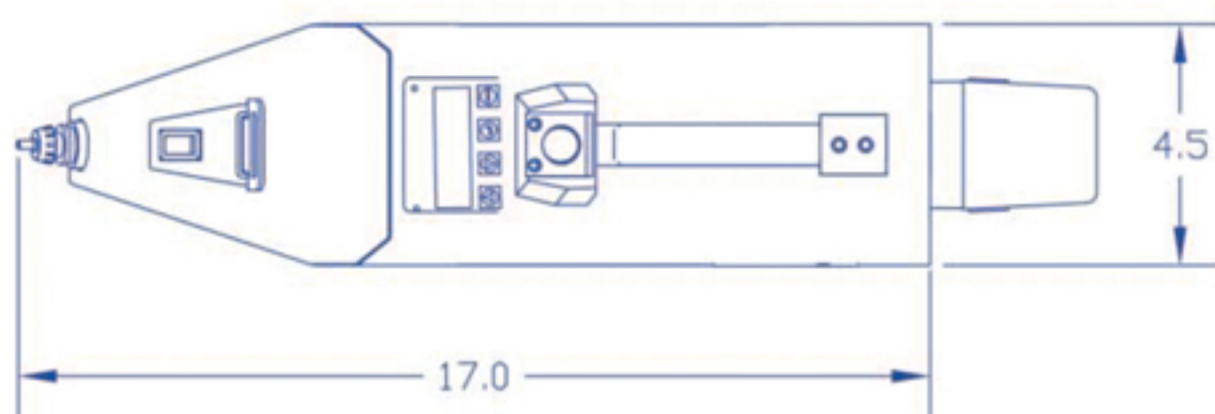

**ISO 9001 REGISTERED**  
**U.S. PATENTS: 4,765,153**  
**4,646,300**  
**U.S. PATENT PENDING: 20040053421**



*"Homeland Security Specialist"*

\*Modifications reserved 2006-2008 © Scintrex Trace Corp. In some cases, images contain options. Information subject to change without notification.